

ECE 2100

Circuit Analysis

Lesson 11

Chapter 3:

Nodal & Mesh Analysis

by Inspection

Daniel M. Litynski, Ph.D.

<http://homepages.wmich.edu/~dlitynsk/>

ECE 2100

Circuit Analysis

Review: Lesson 10
Chapter 3: Mesh Analysis
with Current Sources



Methods of Analysis - Chapter 3

3.1 Motivation

3.2 Nodal analysis.

3.3 Nodal analysis with voltage sources.

3.4 Mesh analysis.

3.5 Mesh analysis with current sources.

3.6 Nodal and mesh analysis by inspection.

3.7 Nodal versus mesh analysis.



ECE 2100

Circuit Analysis

Lesson 11

Chapter 3:

Nodal and Mesh Analysis by Inspection

Daniel M. Litynski, Ph.D.

<http://homepages.wmich.edu/~dlitynsk/>

3.6 Nodal and Mesh Analysis with Inspection (1)

The properties of a super-mesh:

1. The current source in the super-mesh is not completely ignored; it provides the constraint equation necessary to solve for the mesh currents.
2. A super-mesh has no current of its own.
3. A super-mesh requires the application of both KVL and KCL.

3.6 Nodal and Mesh Analysis with Inspection (2)

Example 10 – By inspection, write the nodal voltage equations for the circuit

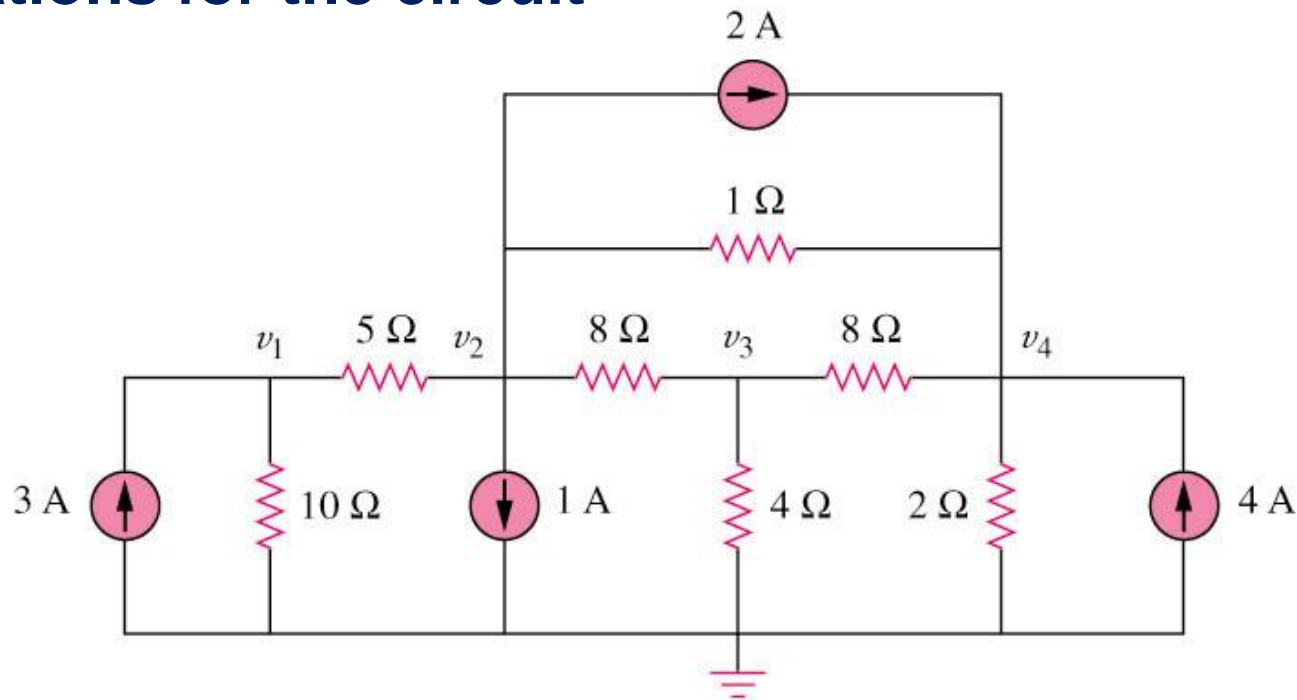

*Refer to in-class illustration, textbook

3.6 Nodal and Mesh Analysis with Inspection (3)

Example 11 – By inspection, write the mesh-current

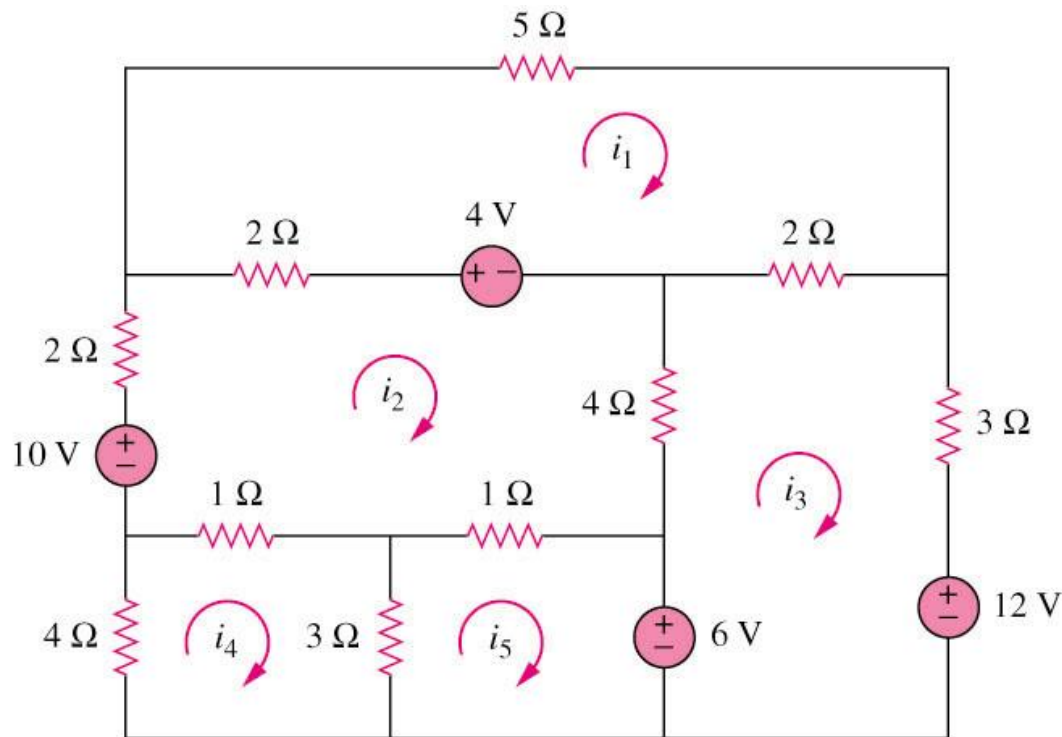

*Refer to in-class illustration, textbook

3.7 Nodal versus Mesh Analysis (1)

To select the method that results in the smaller number of equations. For example:

1. Choose nodal analysis for circuit with fewer nodes than meshes.
 - *Choose mesh analysis for circuit with fewer meshes than nodes.
 - *Networks that contain many series connected elements, voltage sources, or supermeshes are more suitable for mesh analysis.
 - *Networks with parallel-connected elements, current sources, or supernodes are more suitable for nodal analysis.
2. If node voltages are required, it may be expedient to apply nodal analysis. If branch or mesh currents are required, it may be better to use mesh analysis.